



Now with red OR16 CLIP on the tail of the board!

"Often Imitated, Never Duplicated!"

UNFOLD THIS SHEET FOR INSTRUCTIONS



OR12L SIDE PLANER, YELLOW

The OR12 handles rough water better and carries large, deep diving crank baits further to the side than other boards. The OR12 won't roll or dive in the worst fishing conditions. By using our OR16 Clip on the tail of the board, it insures your board will stay on your fishing line! Make sure to place your line **BEHIND** its center pin as indicated.

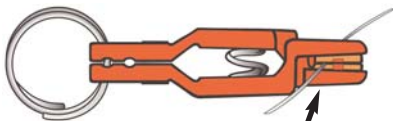

Line placement in (Red) OR16 Clip

THIS PACKAGE INCLUDES: Yellow Side Planer with Stationary Flag, One OR19 Release (Orange), One OR16 Clip (Red), Two 6/32 Screws, Two Nylon Nuts, One Split Ring and Instructions.

(In order to convert this board to a spring loaded Tattle Flag board, you will need to purchase the OR12TF Tattle Flag Kit.)



Go to **offshoretackle.com** for more tips and information!

OR12L



0 23072 60192 0

LEFT

SCAN. TROLL. CATCH FISH.

"Your Leader In Trolling Technology" • Made in the U.S.A.

WARNING: This product contains less than 1% lead, a chemical known to cause cancer, birth defects, and other reproductive harm. Wash your hands after handling this product.

CLEMCO PRINTING – BAD AXE; 10-13; G5

ASSEMBLING THE "PRO RIGGED" BOARD:

No tools are needed to assemble the OR12 board. After removing the board from the package, hand loosen the 6/32 screw and nut, then remove the OR19 (Orange) release. Position the OR19 release perpendicular to the board, then replace the screw and nut. Hand tighten the screw until the plastic pin on the bracket is secure inside the brass eyelet on the release. **(Note: Check tightness prior to setting the board out each time.)**

The **OR12 Off Shore Side Planer** comes with one OR19 (Orange) Heavy Tension Adjustable In Line Planer Board Release on the bracket. *The spring in this release can be slid toward the pads to increase the tension or away from the pads to reduce the tension, depending on the species or conditions to be fished. (Slide the spring by using a key, screw driver, etc.)*

The OR16 (Red) Clip that is on the tail of the board has a unique **center pin** feature that, when you properly secure your fishing line **BEHIND** this center pin, your board will stay on your line!

Additional PRO RIGGING details found on back.

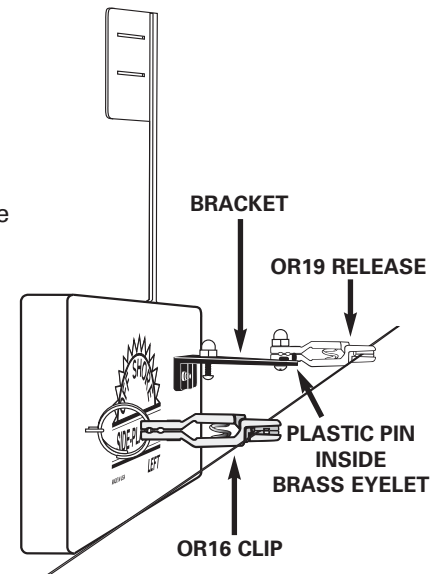

MOST POPULAR RIGGING OPTIONS FOR YOUR OR12 SIDE PLANER

As with all rigging options, once you set up your OR12 the way you want, attach the board to your fishing line, let it out the side of the boat to the desired distance you want your board to run and catch some fish. Once a fish is hooked, slowly reel in the board until it is within reach on boat side, remove the board from the line and continue to fight the fish to the net!

Pro Rigging

Guides, charter captains and professional anglers prefer to use this set up that comes standard on the OR12. You simply secure your rod's fishing line into the OR19 release on the bracket and BEHIND the pin of the OR16 clip on the tail. (See diagram 1.) The weight of the hooked fish will cause the board to sag or be pulled backwards in the water. (Assembly shown in detail on front.)

Diagram 1

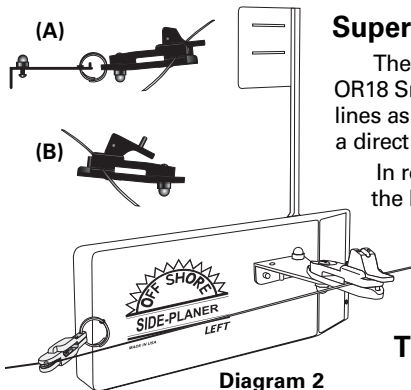
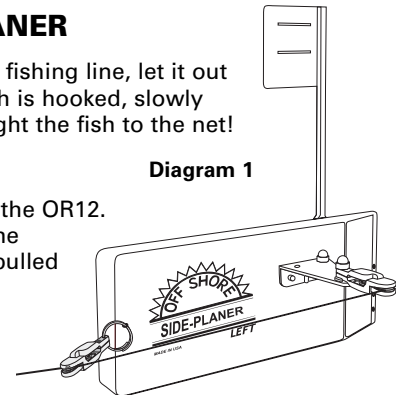

Super Lines, Lead Core, and Copper Rigging

The OR12 is well suited to use with long copper lines and lead core. The OR18 Snapper Release (sold separately) is ideal when using the modern super lines as well as use with copper and lead core line. No other release will hold the line as well as the OR18 Snapper. It is a direct replacement to the original OR19 release with no modifications needed. (See diagram 2.)

In rough water, the OR18 release can be attached to the hole in the end of the bracket by a split ring. This allows the board to follow the contour of the waves easier. With the lever in the forward position on the OR18, it prevents the board from coming off the line via a pin in the front of the release (A). If you prefer, simply snap the lever in the back position, and the release will allow the board to trip and slide back (B).

Tattle Flag Rigging

To make your OR12 a Tattle Flag board, you would need to purchase our OR12TF Tattle Flag Upgrade Kit. Once you install the upgrade, this will give you a spring loaded flag that will be pulled down when a fish strikes the lure. In addition, it will enable you to "read" the board and determine whether it is running correctly, fouled with weeds, or even if you are towing a small fish. An excellent advantage when fishing for light striking fish! (See diagram 3.)

Diagram 3

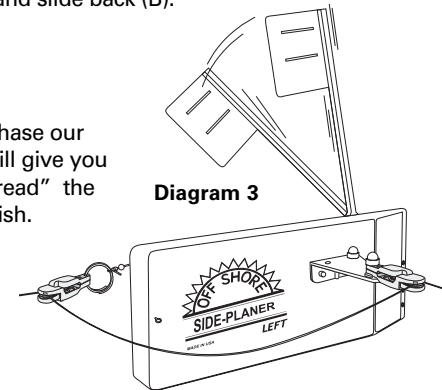

Slide Back Rigging

Rigging your board in this manner is popular with anglers who prefer the planer board to trip and slide down the fishing line when a fish strikes. In this manner, you replace the OR16 clip with a snap swivel or OR12P2 pigtail (both are sold separately) on the tail of the board. To use, place your fishing line into the pads of the OR19 release on the bracket and then through the snap swivel or pigtail located on the tail of the board.

Diagram 4

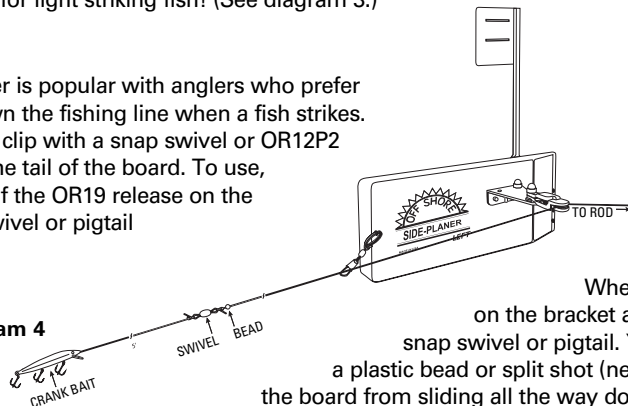

When the fish strikes, the line pops free of the release on the bracket and the board begins to slide down the line via the snap swivel or pigtail. You can set a stop onto your fishing line by rigging a plastic bead or split shot (neither included) a few feet above the lure to prevent the board from sliding all the way down the line and striking the fish. (See diagram 4.)